

Layout Procedures for Metals

Layout Procedures for Metals

MARC ROSE

OPEN OREGON EDUCATIONAL RESOURCES



Layout Procedures for Metals by Marc Rose is licensed under a [Creative Commons Attribution 4.0 International License](https://creativecommons.org/licenses/by/4.0/), except where otherwise noted.

Contents

<u>Introduction</u>	1
<u>Accessibility Note</u>	2
<u>Part I. Main Body</u>	
1. <u>Chapter 1 Flat Pan</u>	5
2. <u>Rectangular Sleeve</u>	12
3. <u>Circumference & Bisecting Angles</u>	16
4. <u>2 piece 90°</u>	23
5. <u>3 Piece 90°</u>	31
6. <u>Branch and Header Connections</u>	37
7. <u>Concentric 90° Branch on Header</u>	38
8. <u>Eccentric Branch</u>	43
9. <u>45 lateral branch</u>	48
<u>Part II. General Notes</u>	
<u>Appendix-pipe table</u>	59

This booklet will lay out step by step procedures and how they can aid a crafts-person to build templates to build both simple and complicated fabricated parts. Types of materials that can be used with these templates is a combination of flat sheet and round tube or pipe.

In order to be successful in the use of this booklet you need to have a good understanding of basic blueprint reading skills, industrial math skill and also basic geometry. Couple this with welding and fabrication skills you can produce a wide variety of fabrications and weldments.

This booklet will start off with simple flat patterns and work in to more complex templates for pipe.

Accessibility Note

Because the graphics in this book are difficult to describe verbally, the Center for Accessibility Resources (CFAR) at Linn-Benton Community College (LBCC) has determined that tactile graphics would be a better solution for learners who have low or no vision. LBCC students in need of accommodations can contact cfar@linnbenton.edu.

PART I
MAIN BODY

I.

We will start out with a flat pan template build. This will be one the simplest template we will construct, but there are key components of this simple template that will follow through to more complex templates.

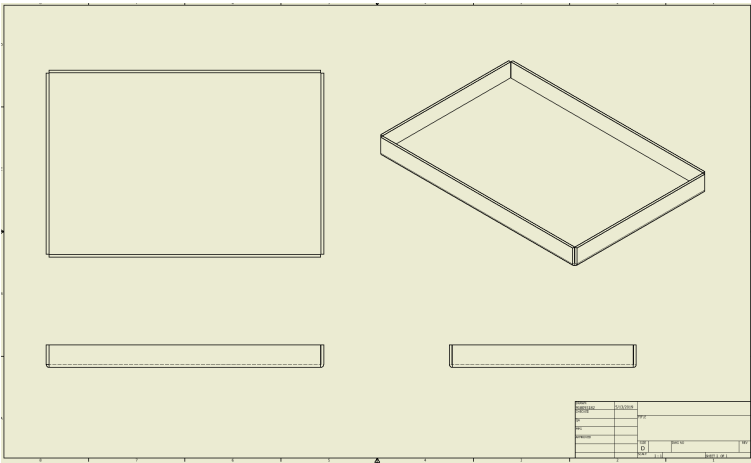

Here we have both the perspective view and an orthographic drawing. Using this format it is easy to see what the finish product will look like. What we have to do here is reverse the process to see what shape we have to start with to build the pan. The one thing we need now are dimensions.

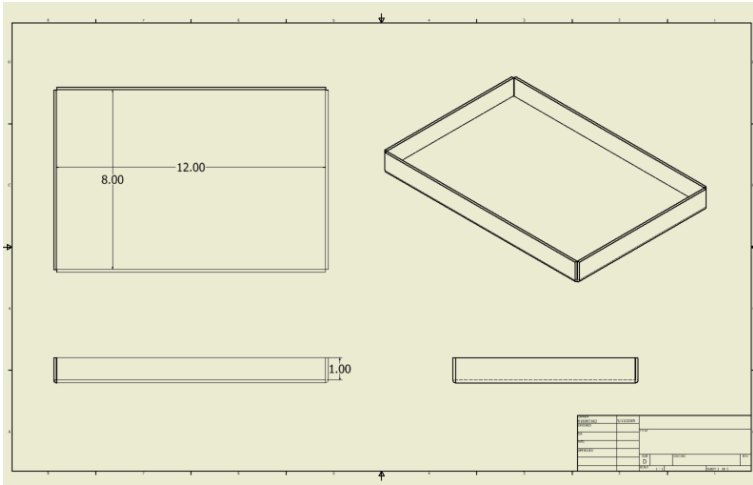

Now that we have the parts overall size we can determine how to go about laying this part flat and work with the dimensions given so we can create the pan.

By inspecting the drawing we can see that the over flat portion of the pan or the inside dimension is 8" x 12". Each side has a total inside height of 1" each. By adding these together we can tell that what we will need to material to build the pan. This can commonly be called the *STRETCHOUT*. $8" + 1" + 1" + 12" + 1" + 1"$ gives us an overall sheet size needed of 10" X 14".

Before we get too far, let just draw the inside base of the pan.

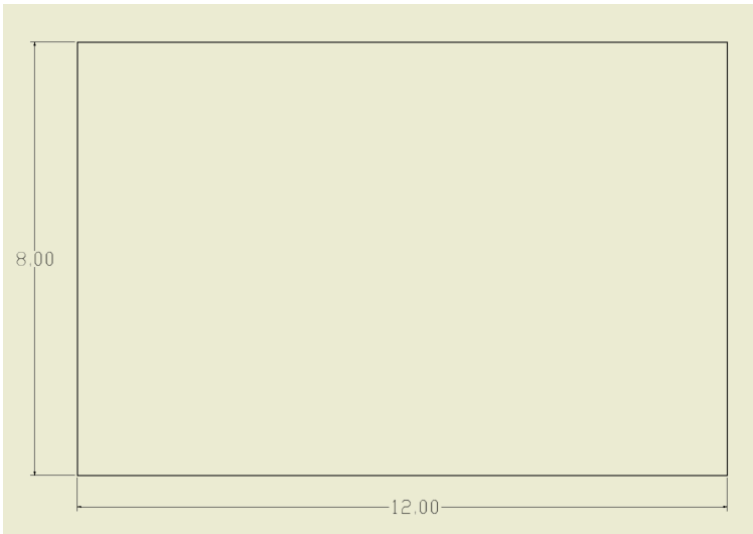

A simple rectangle that measure 8" x12".

Now we need to add the 1" to all four corners that will become the edges of the pan. First you need to extend each line by 1" at each corner.

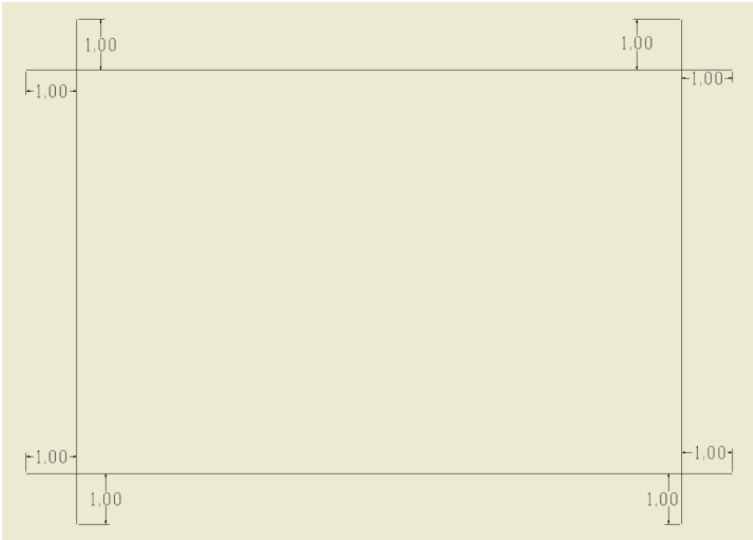

Now we simply connect a line on each side for each 1" extended line.

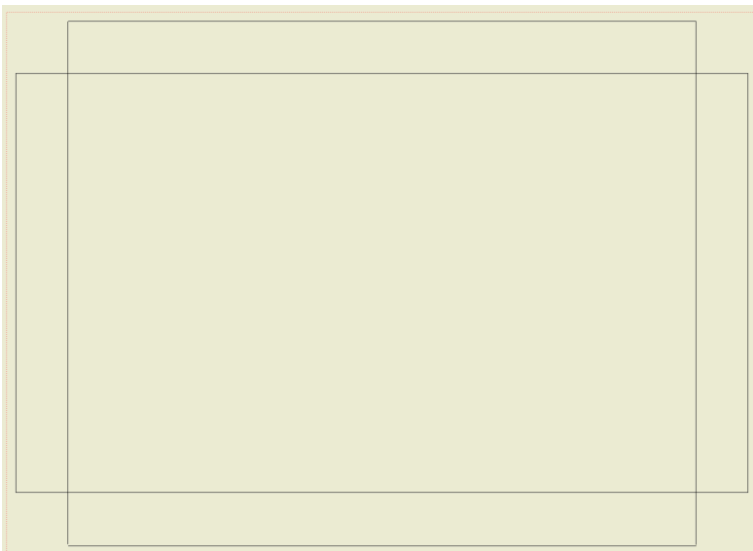

Now you can see in each corner there is a square notch. These notches allow 1" portion of the sheet to be bent up 90° to form the pan.

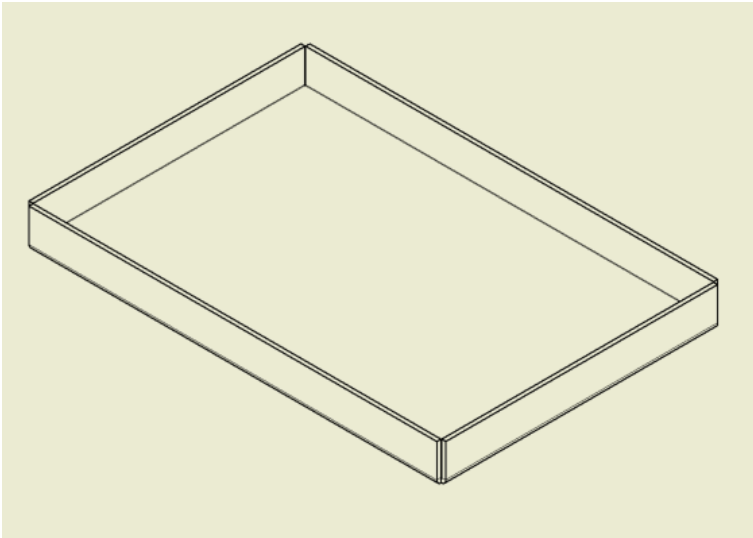

After sides are bent at 90°, the finish product should look like this.

Notes about flat sheet layout and dimensions.

You need to pay attention to how the parts are dimensioned, inside or outside. If parts are dimensioned to the outside you will need to account for material thickness for each formed edge to properly determine **Stretch-out**. The **Stretch-out** will be based off of the inside surface. For each 90° bend .12" will be gained to overall length.

For example:

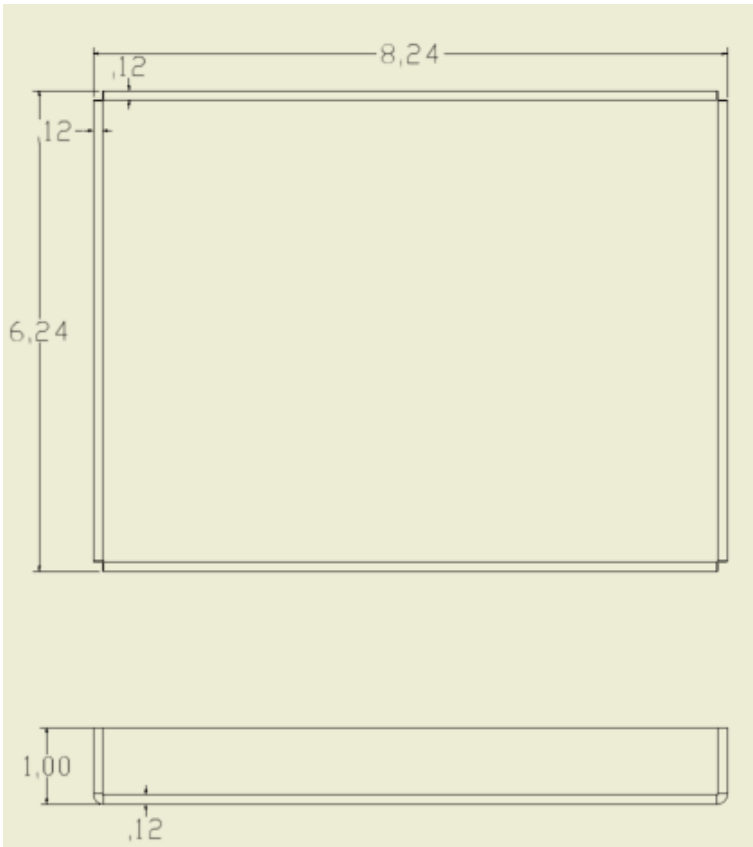

The outside dimension are 6.24" x 8.24" x 1" tall. To figure out what inside dimension is for bottom of pan for layout we need to take 2 x the sheet thickness minus the given outside dimension. The inside dimension of pan is 6" x 8" with an inside height of .88".

To figure the **stretch-out**, we will need to add $6" + .88" + .88" = 7.76"$ and $8" + .88" + .88" = 9.76"$

The flat **Stretch-out** will look like this:

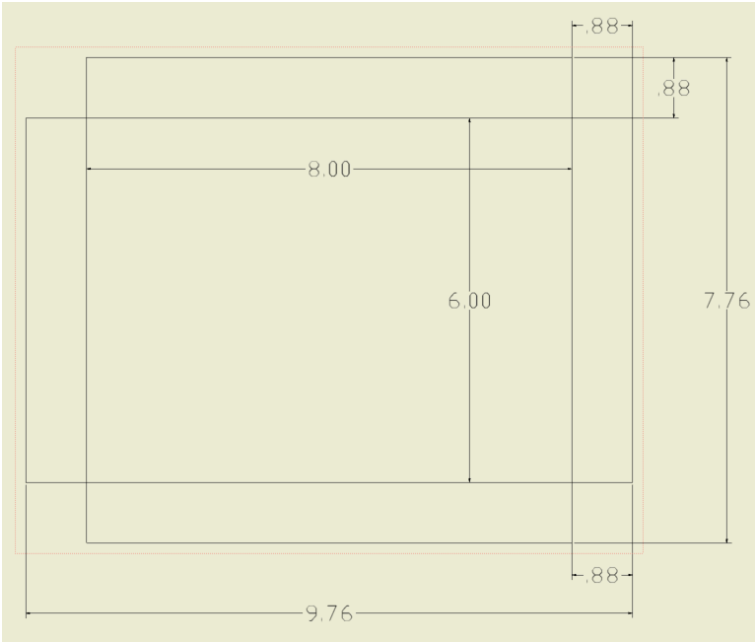

2. Rectangular Sleeve

For this example we want to build a template for a “chimney” or sleeve that will rest on a sloped roof surface. The roof surface will have a slope of 30° and the sleeve will have the dimensions of the drawing below.

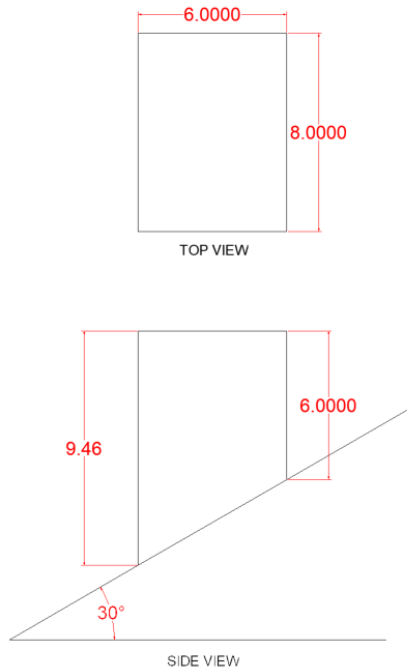

Now that we have needed measurements we can begin to draw the stretch-out.

To help keep everything in order it helps to number points on stretch-out so they match up to each corner. Since this part will have a seam, we can use “0” to indicate the seam. Looking at the

side & top view we can see that the points 1&4 have the same height as well as points 2&3 since they are in the same plane. The blue lines are there to show how the lines to extend to help develop the stretch-out.

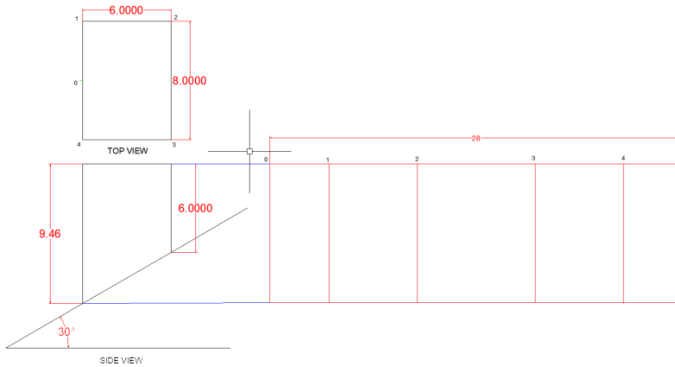

Next we will transfer the measurements from the side view to the stretch-out to determine the shape of the template.

We know at points 0, 1 & 4, the height is the overall height measure at 9.46", since all those point are in the same plane in the side view. For points 2 & 3 we can see that the overall height there is 6". We need to transfer this to the stretch-out. There are a few ways to this function. You can simply measure 6" down from each point on stretch-out at points 2 & 3 and mark it with a tic mark, you can also transfer the line 90° to the right and where the horizontal line intersects points 2 & 3 place a tic mark.

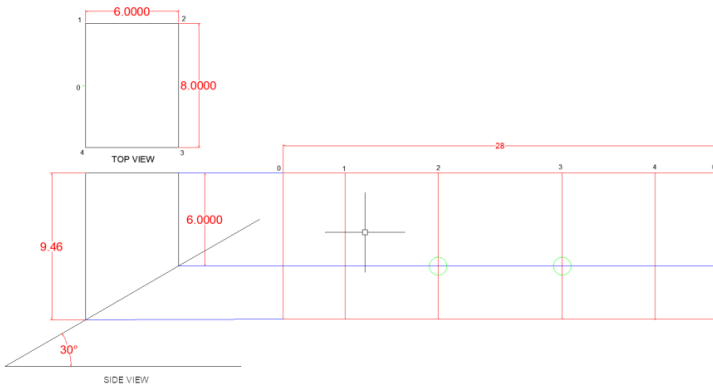

Now we can add a couple lines connecting the base of the stretch-out to vertical line 2 & 3 to show what the final shape of stretch-out will be. We can also remove any lines we used to transfer features from side view to stretch-out. The green line indicate the sheet size and shape the red lines indicate where the sheet will be formed.

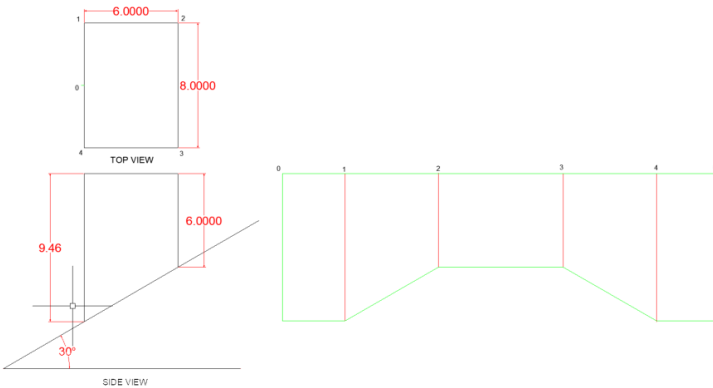

3. Circumference & Bisecting Angles

CIRCUMFERENCE AND HOW TO FIND

There are a few ways to find the circumference of pipe and round tube. Knowing the circumference is key into building accurate templates for use with pipe. The more accurate your numbers are when developing these template, the better fit you will have. As with anything, practice and experience in building templates will also increase accuracy.

The most used method for figuring circumference is using the formula of $\text{Pi} \times \text{diameter}$. 6" OD round tube has a circumference of 18.85". $6" \times \text{Pi} = 18.85"$. When it comes to working with pipe, you need to be aware that pipe is measure nominally. This means that 6" pipe is not 6" OD. Luckily, all pipe manufactures follow a standard and there is a countless number of tables and charts that list all pipe sizes and even include the circumference of all sizes! Please refer to index to locate these tables, charts and other information.

Over the next several sections we will begin to develop templates for use with pipe. No matter the complexity of the template there are several key concepts that are used with all of them, including determining the circumference. We will only introduce these concepts in detail once, if you need help please refer back to an earlier sections.

We will be talking about dividing the circumference of pipe into several equal parts that will help develop the template. We will refer to these lines as element lines. The more element lines you have the more accurate the fit.

Like was stated earlier, there are many ways that craftspeople have figured out solutions to complex problems, this is book offers one of those.

Below we have some 4" pipe. By referring to the chart we can

see that the OD of that pipe is 4.50". Also on the chart we see that it has a total circumference of 14.125". For this book, we will divide all circumferences into 16 equal spaces in which will become the element lines. The handy chart in the back also shows us the spacing for dividing circumference into 16 parts, as well as 12, 8, 6, 4 and 2. Remember, the more element lines you have the more accurate your template will be. If we did not have the chart, you would have to divide the total circumference by the number of spaces needed. Some rounding will be required when doing this but you need to be aware that being off $1/16$ ", 16 times will end up being off by a full 1".

If you divide 14.125 by 16 you end up at .883. The chart in the back state .875. .875, or $7/8$ " is much easier to work with on a tape measure than .883. The difference is about $1/132$ per line, this will be acceptable.

To get started we will draw a side view that will show the height of our section of pipe. Next we need to draw in our stretch-out. We know the circumference is 14.125. We can draw a vertical adjacent to side view a pipe and then extend out the horizontal lines (shown in red) that are the top and bottom lines from side view to establish the overall height of the pipe and run them out to a length of 14.125". Once we have the height and stretch-out complete we are

ready to place the element lines.

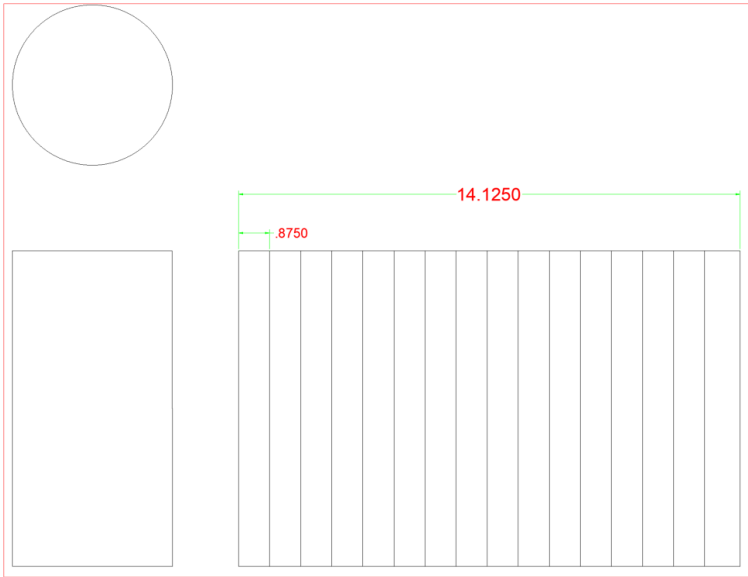

When working with pipe and developing templates you will need to brush up on some basic geometry and the bisecting of angles. We will use a compass for this task.

Below we have angle CAB with a vertex of point A.

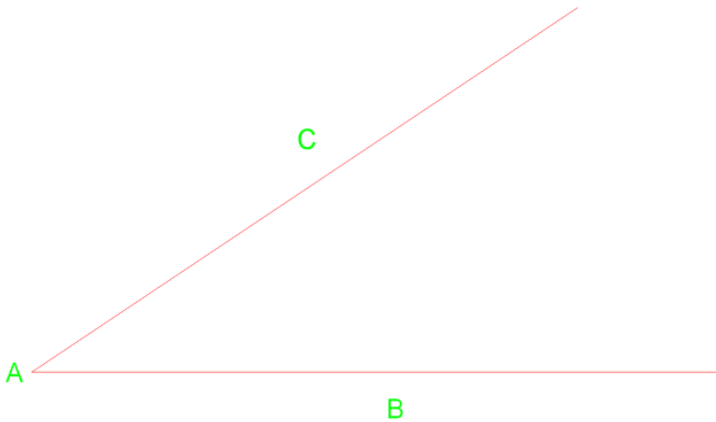

First we can draw an arc from vertex A that crosses the line near point C & B. From those two intersection we can then draw two additional arcs to the right.

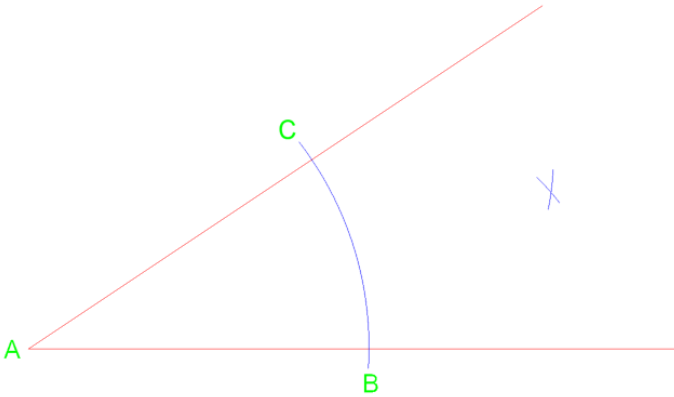

From vertex A draw a line that crosses at point D where the arc intersect.

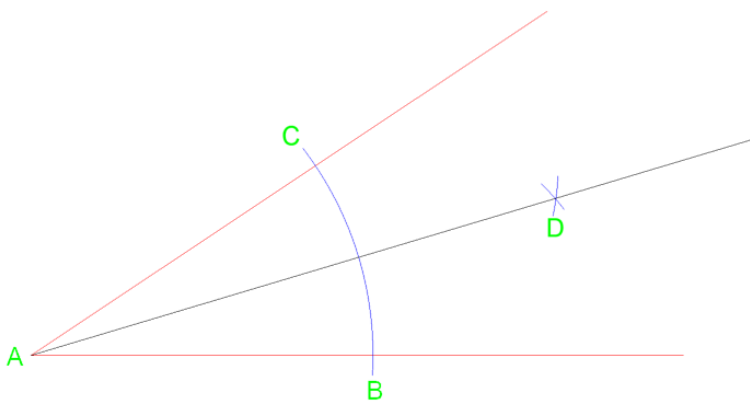

Using this method will equally split the angle into two angle of the same measurement. This method and can repeated if necessary to split it again into 4 equal parts.

Lets try a similar method on a circle. The drawn circle has a diameter of 3" so a radius of $1\frac{1}{2}$ ".

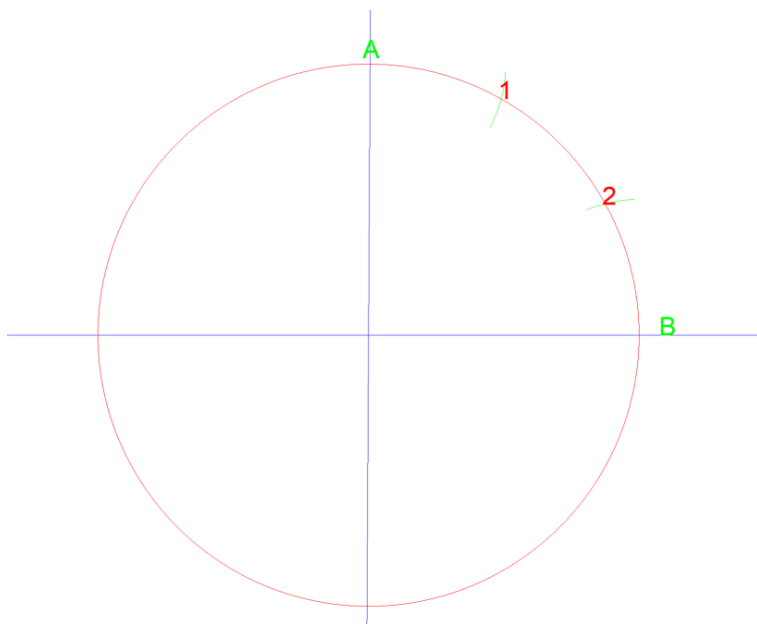

By setting your compass to the radius of the circle, $1\frac{1}{2}$ " and then drawing an arc from point A and then B they intersect at 1 & 2. If you then to draw a line from the center of the circle to each point, you just divided that quarter of the circle into three equal parts. See below...

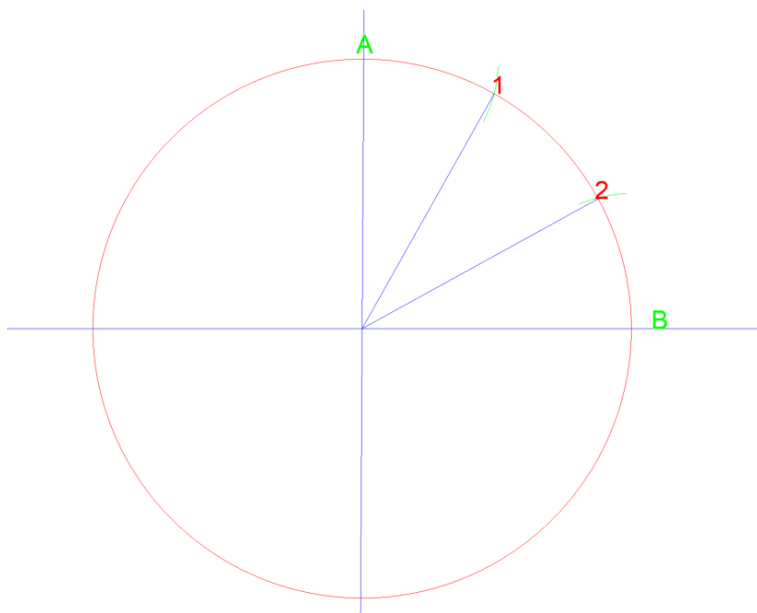

If you then did this again between A, 1, 2, & B you can divide that quarter of a circle into 6 equal areas.

As we covered briefly earlier, we use numbers to help with lining up of where lines will connect. These lines will be used when we are joining two or more parts together to make one assembly. As we keep going, you will better understand how this numbering system works.

4. 2 piece 90°

Depending of what size of pipe you are working with will determine what size of paper you need. Typically you will work with the paper in a landscape(sideways) orientation. Once it is confirmed your template will work, you can then trace your working template onto heavier paper or sheet material that you can easily reuse time and time again.

We will be constructing a template to help us generate a 2 piece 90° elbow. With some basic geometry we know that the two angles that make up a 90° are 45°. To start with we will draw a view that shows the pipe and the miter cut joint.

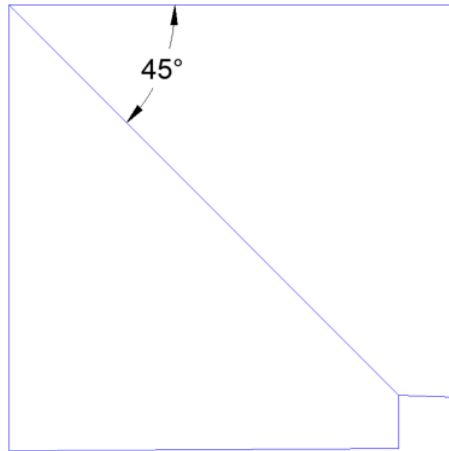

Lets remove one half of the elbow to begin making our template.

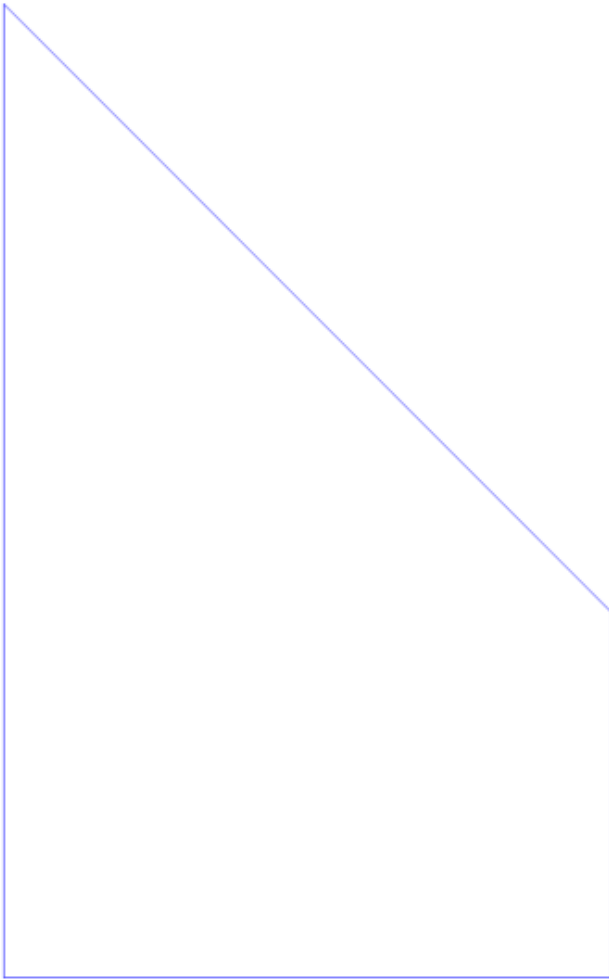

Now let's draw a half circle off the bottom end and divide that into 8 equal parts. Number each place where a line intersects the arc of half circle.

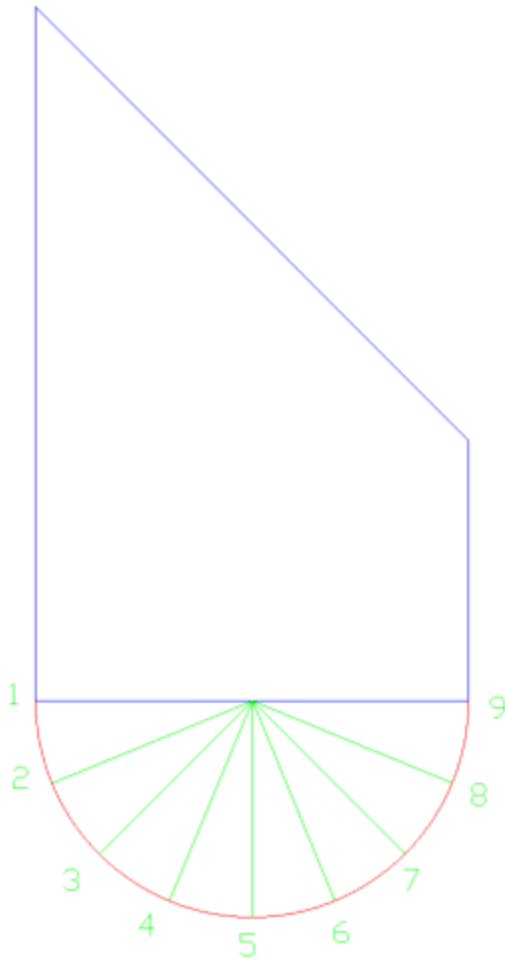

Now, at each point on the arc draw a straight line from arc to where it intercepts the 45° line. Those are you element lines.

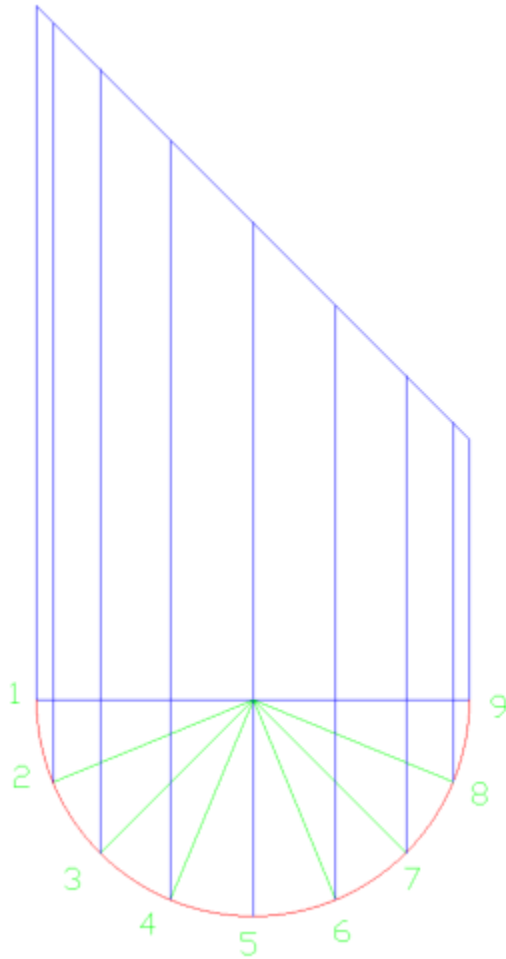

Now we will construct the stretch out of the template. Extend the bottom and top lines to the right from the first view drawn. The overall length of your stretch out will be determined by the

circumference of your pipe. The green line indicate how we transfer the overall height of object to the stretch-out.



Now divide your stretch-out into 16 equal parts.

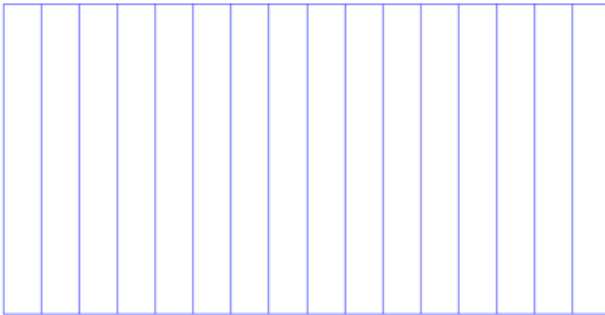

Now we have both the stretch-out and the side view in alignment and can start to transfer elements over to the stretch-out.

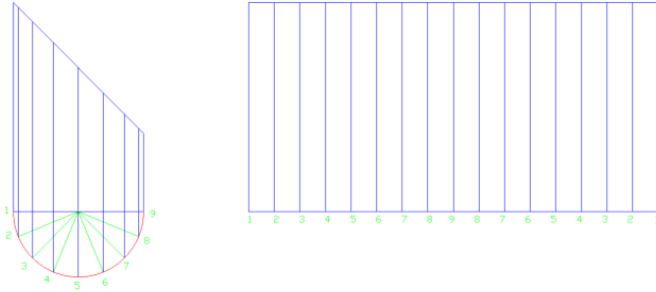

The numbers will correlate to each other from one drawing to the other. Place a straight horizontal line from mitered line over to the stretch-out and where the numbers math-up, make a tick mark.

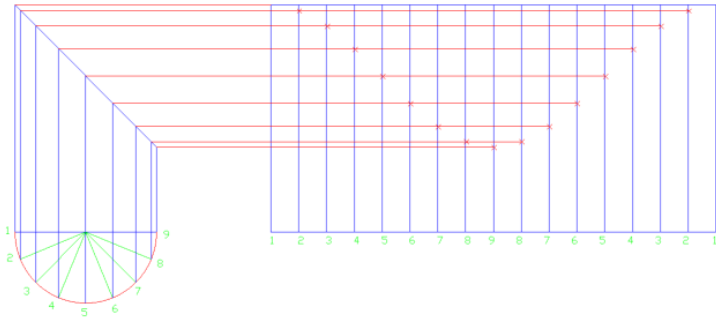

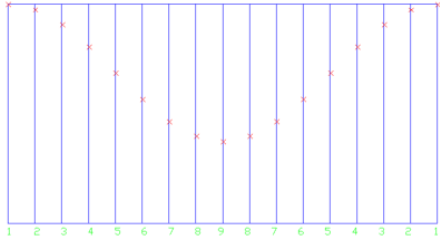
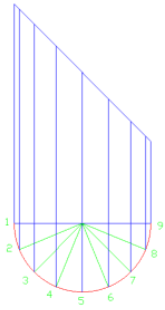

Now with connect a line between tick marks with a curved line.

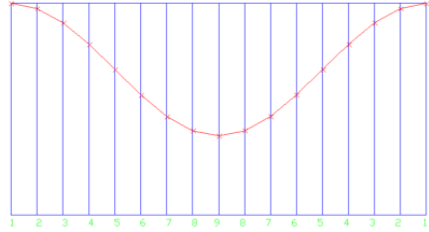
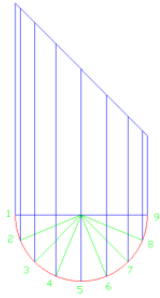

You can now remove the top section of lines above the curve on the stretch-out. Cut your template out and it is ready to use.

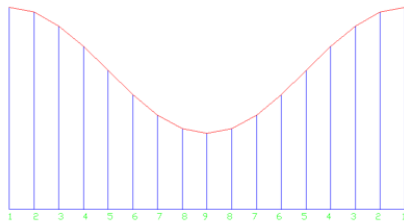
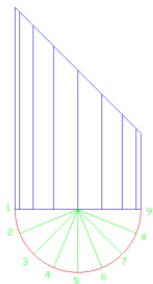

Now you can take the stretch-out and wrap around your pipe, trace the curved line onto pipe and proceed to cut.

5. 3 Piece 90°

Three piece turn-

We know that when building a two piece 90° turn we needed to cut two pieces at 45°. When making a three piece turn we will need to add one more piece of pipe and thus change the angle we need to cut.

The plan view of the joint will look like this. We have bisected the joint to show what the finished angle will be, once our template is completed.

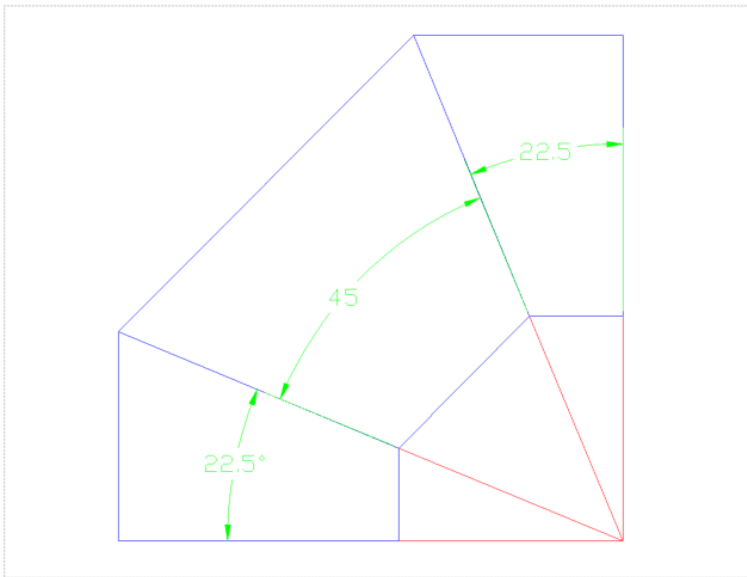

When will use the center portion of our elbow to make our stretch-out and begin to develop the template.

As before, we will draw a half circle off one end and also draw our stretch-out. The green lines are to show how to transfer elements

from one drawing to another. You will need to calculate the stretch-out depending on what size pipe you are working with. Since we will be making a template that can be used to cut two ends at same time, the dark line on stretch out is in reference to center of stretch-out.

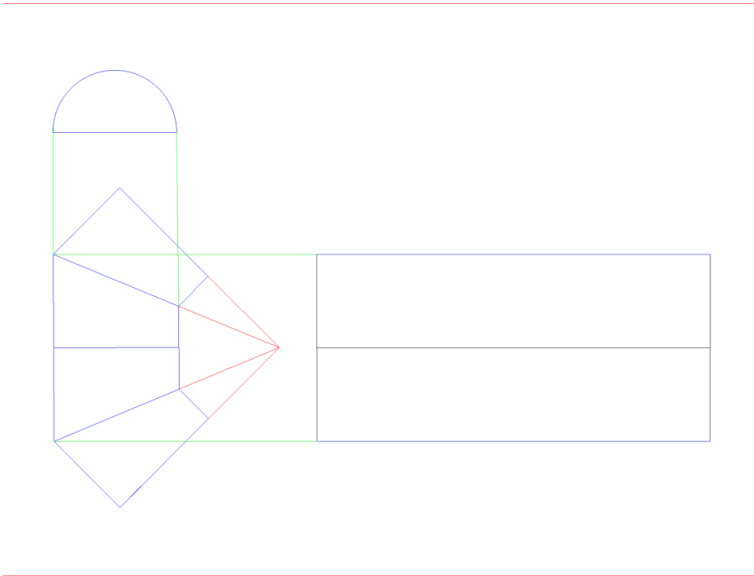

Next we will divide the half circle into 8 equal parts and the stretch-out into 16.

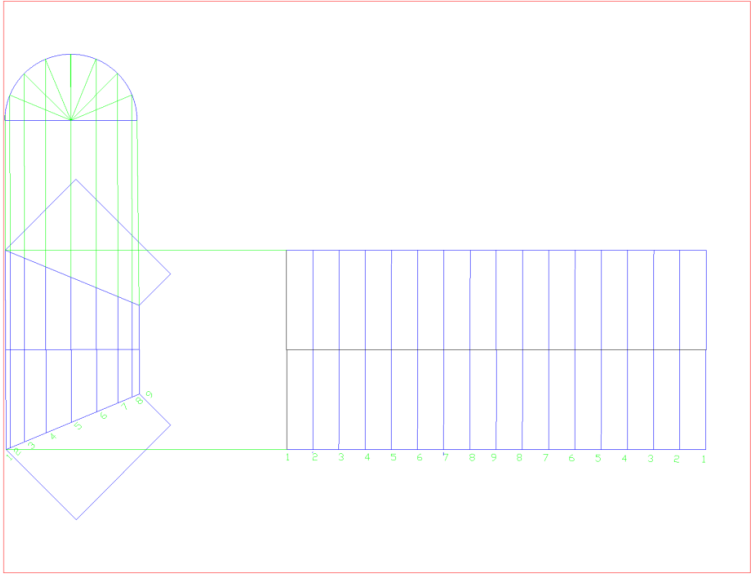

Now we can transfer elements to the stretch-out. Indicated by dashed lines you see how they reference the numbered lines on each drawing.

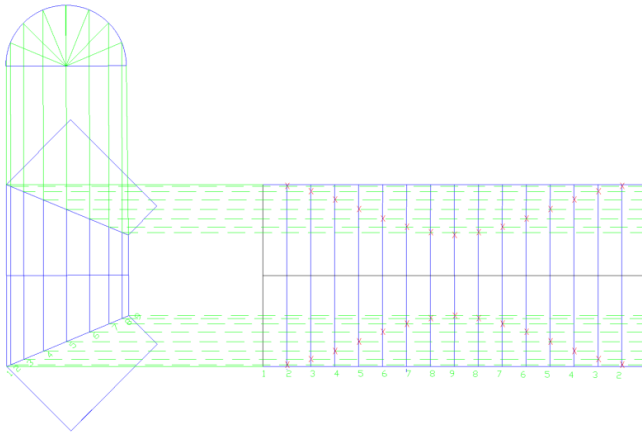

Now we can draw in our curved line to all tick marks giving the template shape.

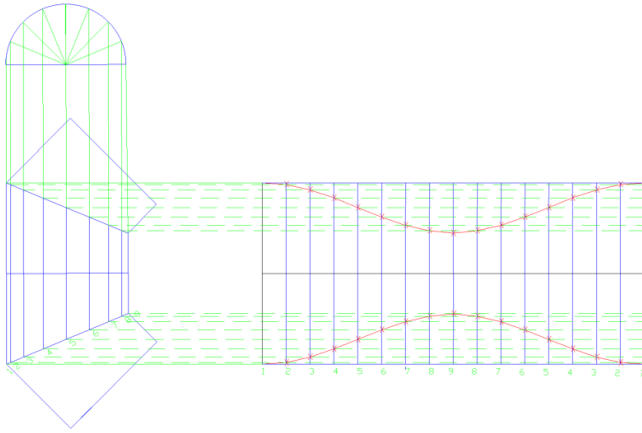

Now remove all the non-essential lines and what is left is the final shape of the template.

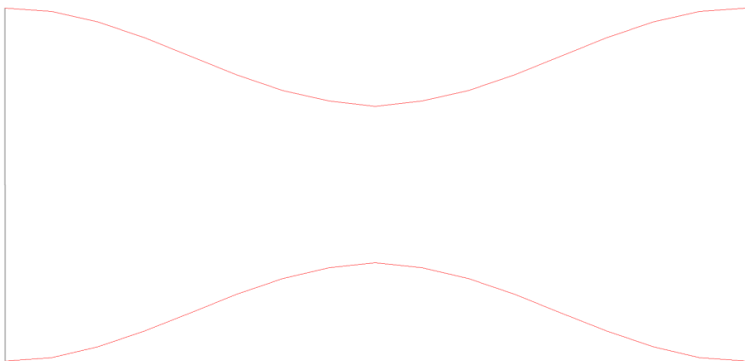

You can take your template, wrap around pipe, trace the patten and then cut and fit.

6. Branch and Header Connections

Many times in the piping industry there is a need to make a connection to a pipe where it is not practical or feasible to use a manufactured fitting or it is not possible to do so. These types of connections are sometime called branch and header connections. The “Header” is the main line that is being tied into and the “Branch” is the line come off of the Header. The branch is either the same size as Header or smaller in size.

We will go over three types of templates for making these types connections. We will use all of the tools from the two and three piece 90° turns covered in previous chapters.

7. Concentric 90° Branch on Header

Concentric 90° branch

This fitting is *Concentric*, meaning the branch and header are on the center line.

We will begin by drawing the header pipe from an end view and the branch connection on same center line directly above. *Remember, all pipe regardless of wall thickness has the same O.D. so we will only worry about drawing the O.D. lines and not worry about the I.D.*

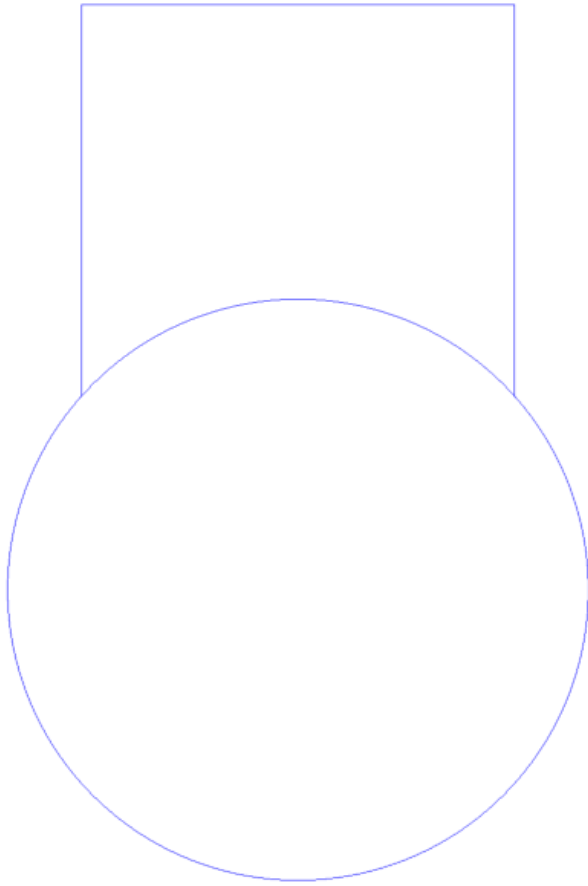

Now we will draw the half circle on end of branch and extend out the height of branch and draw the stretch-out. *You will have to verify size of pipe or refer to chart to find total circumference.*

Green lines are to show the extension of branch to develop the stretch-out.

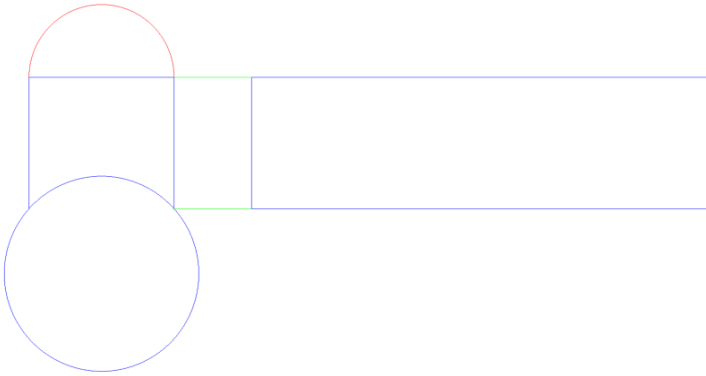

Now we can divide up the stretch-out into 16 equal spaces and divide the half circle up as well. *Note: Since this is a concentric branch and everything is off of center, we can get away with only dividing half the half circle, it is a mirror of the other side.*

Remember to number each line...

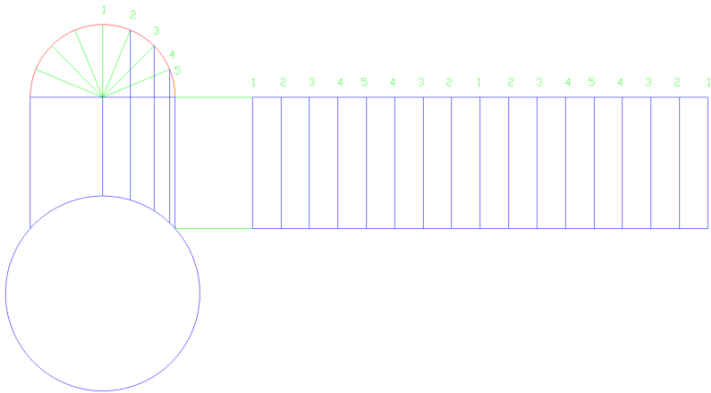

Now we can transfer lines from end view to the stretch-out and number match them and place out tick marks.

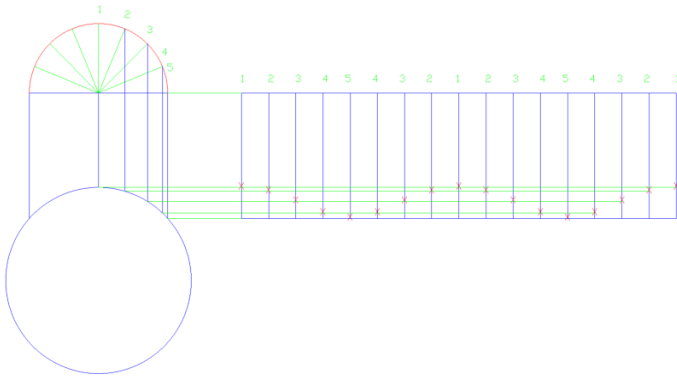

Now we can draw our curved line between tick marks and remove transfer line.

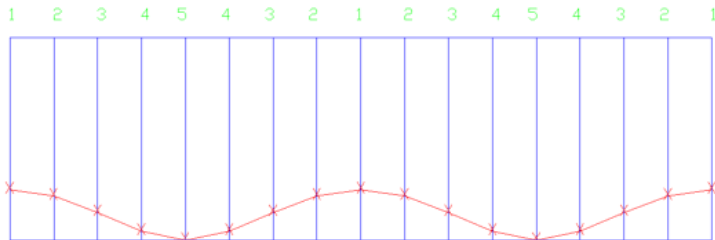

Remove the non-essential lines and the template is ready to use.

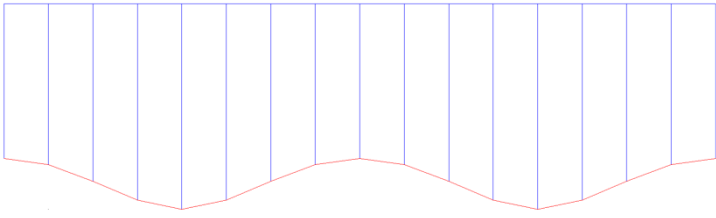

8. Eccentric Branch

The procedure for the Eccentric and Concentric are near identical. The only real difference comes into the fact that the Eccentric branch is off center. If you remember back when we divided up the half circle for the concentric, we could get away with only laying out half because it was a mirror image. The Eccentric is off center and to show the details of where the lines intersect, we will divide up the entire circle.

Let get started by drawing the end view of Header and Branch. You will notice that the Branch is off of the center line of the header. This offset will be determined by layout needed to make up this fitting and may vary depending on what the situation dictates.

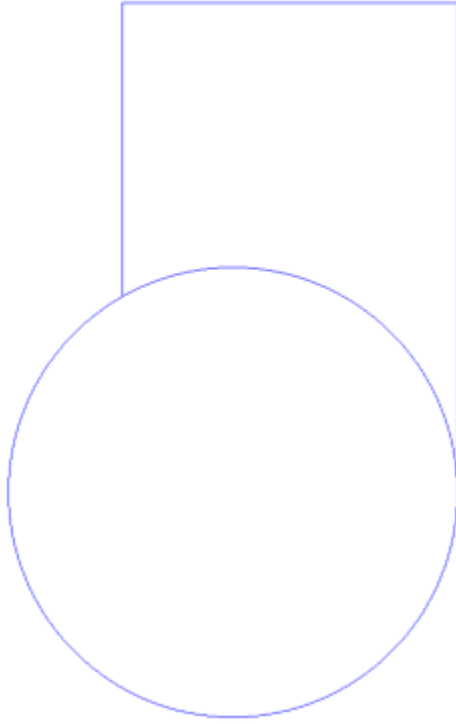

Now we will draw the half circle on end of branch and extend out the height of branch and draw the stretch-out. *You will have to verify size of pipe or refer to chart to find total circumference.*

Green lines are to show the extension of branch to develop the stretch-out.

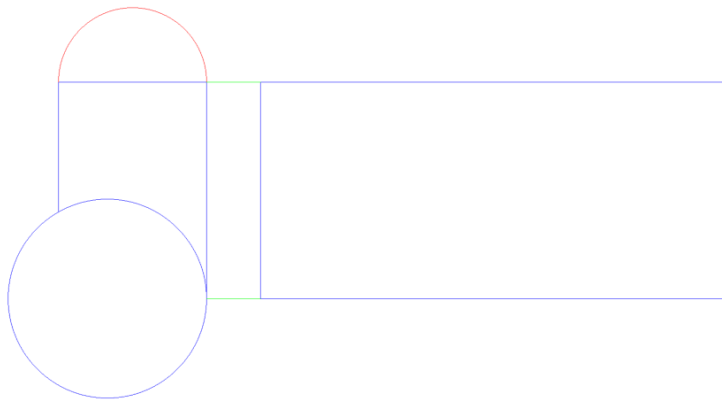

Now we can divide up the stretch-out into 16 equal spaces and divide the half circle up as well. *Note: Since this is an eccentric branch and it is not on center. We have to divide up the entire half circle.*

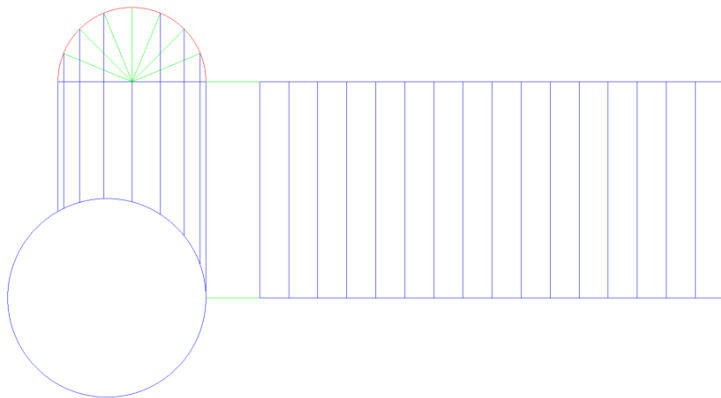

Now we can transfer lines from end view to the stretch-out and

number match them and place out tick marks. Remember to number each line as well.

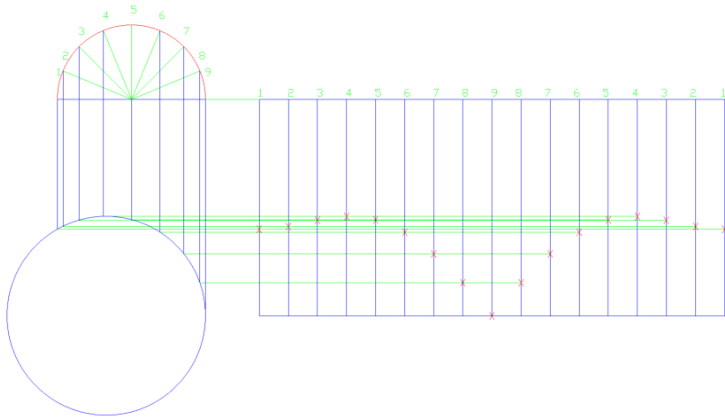

Now we can draw our curved line between tick marks and remove transfer lines.

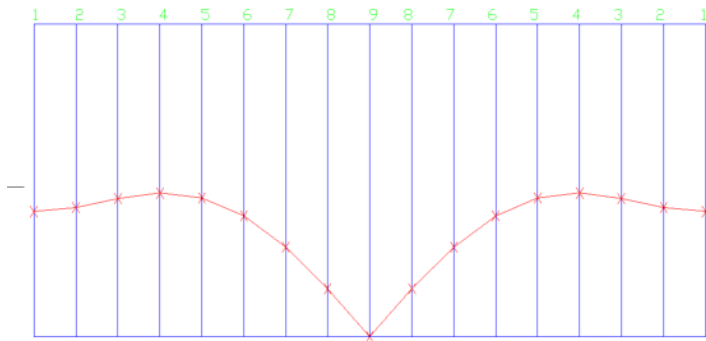

Remove the non-essential lines and the template is ready to use.

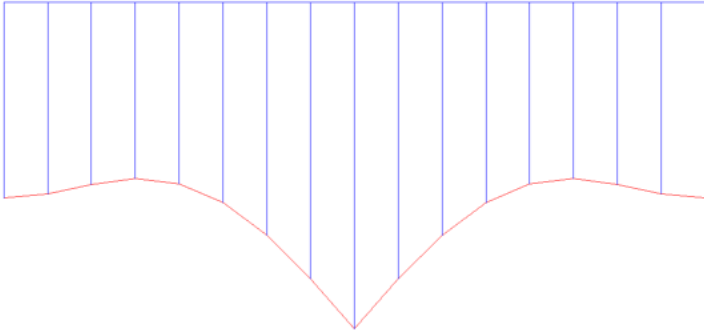

9. 45 lateral branch

45 degree lateral

We will begin by drawing a side and end view of what we want the fitting to look like. Depending the size of pipe you use, your drawing may differ. Refer to pipe chart to find the correct size OD piping material. This example is for 45 degree fit, you can draw this to any angle you may need and use the same steps.

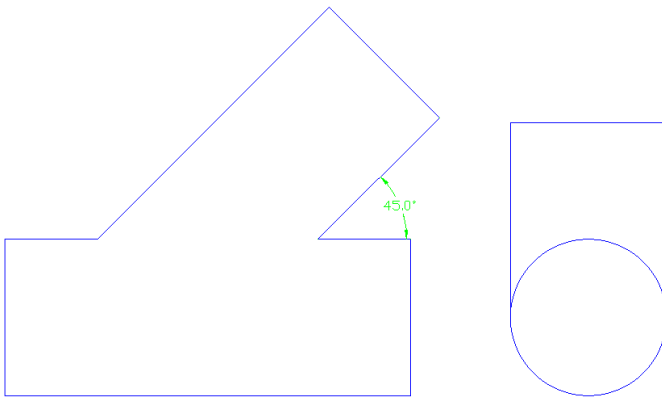

Now as before, we will draw half circle on the ends of pipe and divide them up into equal parts to help develop our element lines. Remember to number the lines as well so when we draw out the stretch-out.

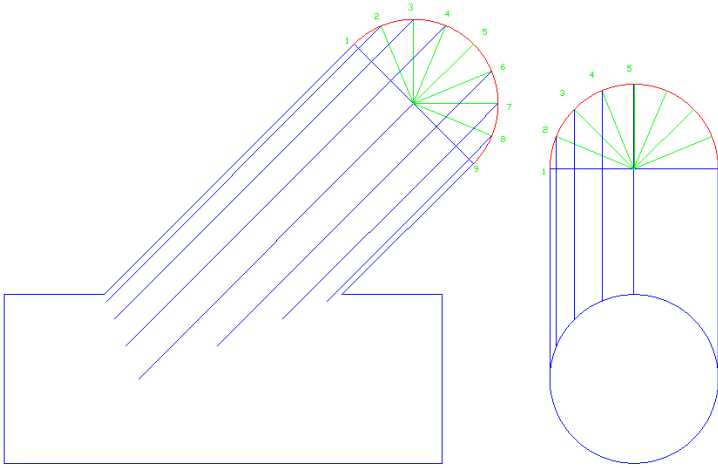

Now we can draw lines horizontally between the two views to help develop the first set of lines we will need. Line up and draw from point 1 to point 1 and so on through point 5. You will notice how the lines will go straight through line 6, 7, 8 & 9. Since this is a concentric reducer from end view, the points will be the same on both side of the pipe. Place a tick mark and each point of intersection.

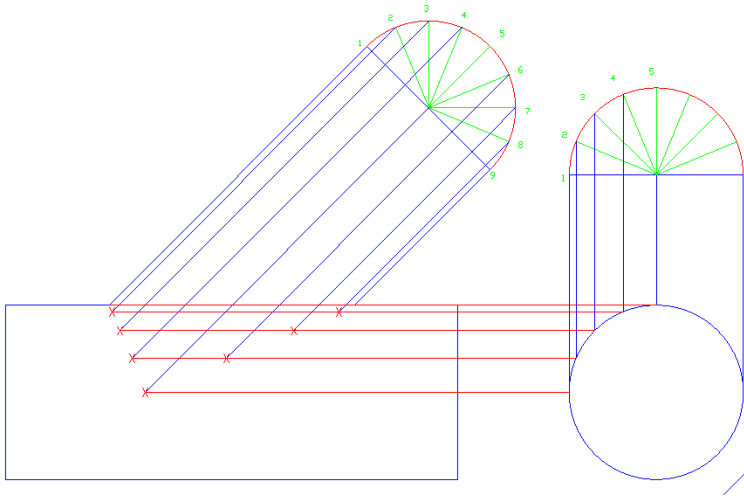

When you draw a curved line from tick mark to tick mark it will look like this.

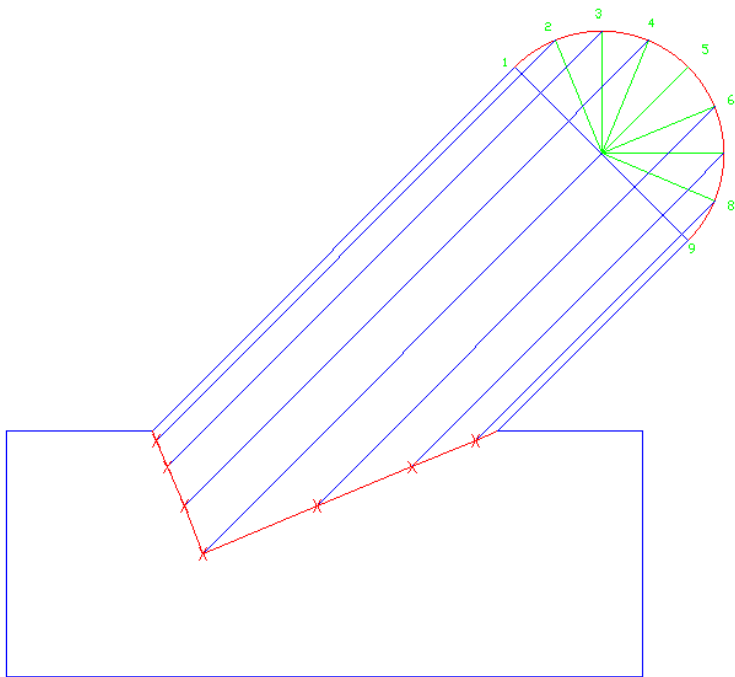

Now we can make our stretch-out from the 45 lateral and divide up as we have on past templates. Divide the stretch-out up into 160 equal spaces.

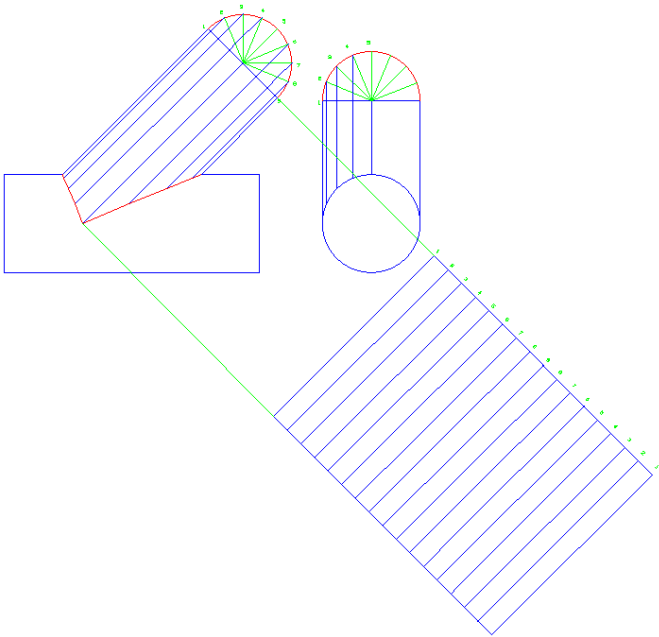

Now we can transfer lines at a 45° angle down from the side view and connect them to same number lines on the stretch-out. Place a tick mark on each point that intersect with the same number as that of where the line originated from.

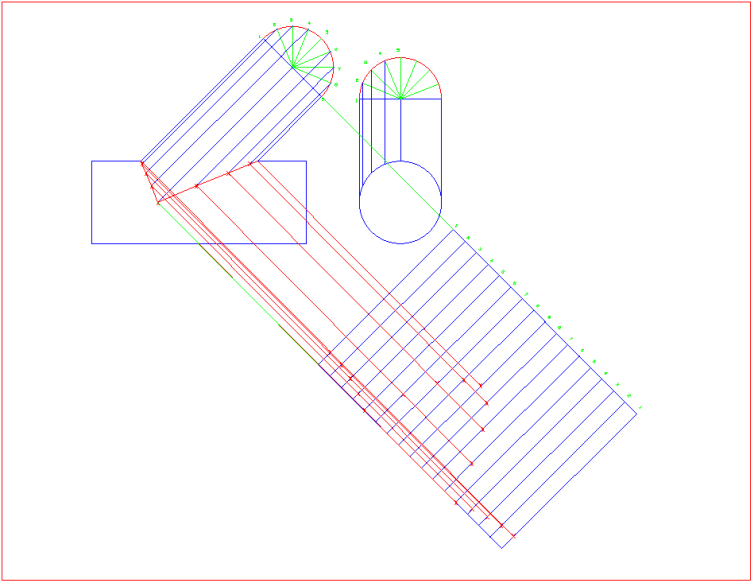

Now we can connect between tick marks and draw in our curved line.

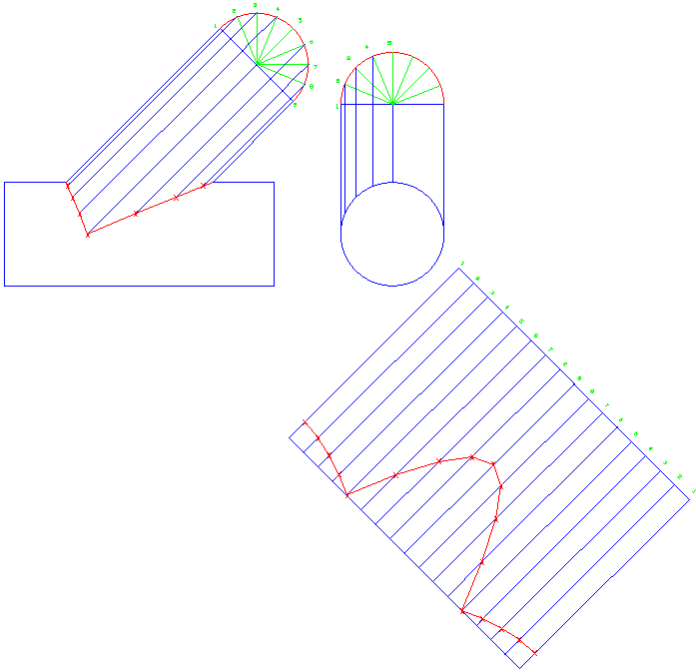

Getting rid of all the nonessential lines our template is ready for use.

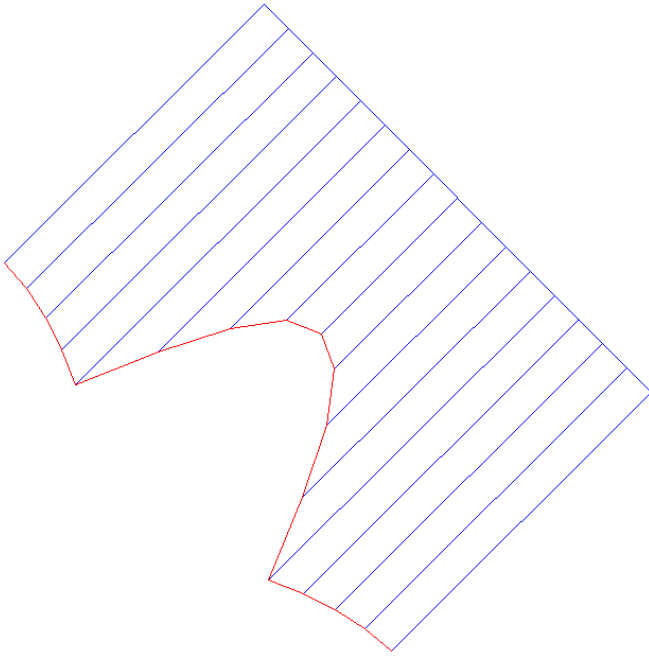

PART II

GENERAL NOTES

In order to work with templates you need to have a good understand of blueprints and orthographic drawings.

A craftsperson should be able to look at any drawing and determine what is to be built and or fabricated. This person should be able to look at a pictorial drawing and in-vision what the orthographic would look like and vice versa.

You must be able to identify line types and there uses and what features the lines are trying depict.

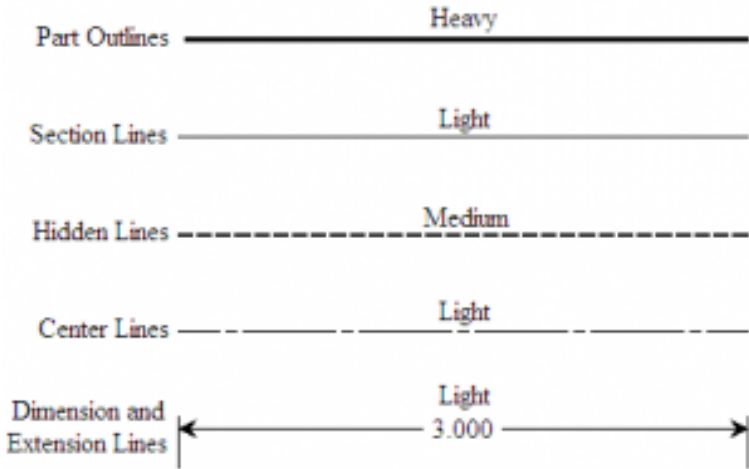

ORTHOGRAPHIC REVIEW

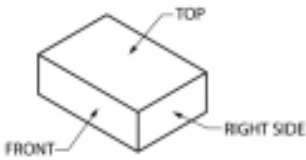

When seen on a print, using orthographic projection, it would appear like this.

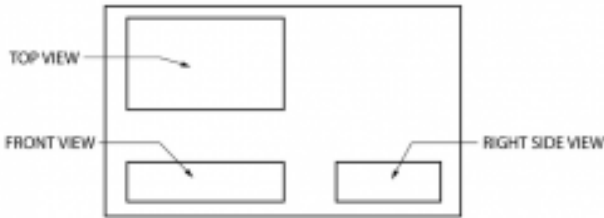

There will be times when you will have to in vision either the perspective view or the orthographic drawings to help you through the build process. It is sometimes helpful to make even a hand sketch of the missing drawing to help you see what is being built.

PIPE SIZE	O.D.	I.D. (SCH 40)	O.D. CIRCUM	CIRCUMFERENCE DIVIDED INTO---												
				1/2	1/4	1/6	1/8	1/12	1/16							
1/8	0.405	0.269	1-9/32													
1/4	0.54	0.364	1-11/16													
3/8	0.675	0.493	2-1/8													
1/2	0.84	0.622	2-5/8													
3/4	1.05	0.824	3-9/32													
1	1.315	1.049	4-1/8													
1 1/4	1.66	1.38	5-7/32								2-5/8	1-5/16	21/32			
1 1/2	1.9	1.61	6-1/4								3-1/8	1-9/16	25/32			
2	2 3/8	2.067	7-7/16								3-3/4	1-7/8	1-1/4	15/16	5/8	7/16
2 1/2	2 7/8	2.469	9								4-1/2	2-1/4	1-1/2	1-1/8	3/4	9/16
3	3 1/2	3.068	11	5-1/2	2-3/4	1-13/16	1-3/8	15/16	11/16							
3 1/2	4	3.548	12-9/16	6-9/32	3-1/8	2-3/32	1-9/16	1-1/16	3/4							
4	4 1/2	4.026	14-1/8	7-1/16	3-17/32	2-3/8	1-3/4	1-3/16	7/8							
5	5 9/16	5.047	17-1/2	8-3/4	4-3/8	2-15/16	2-3/16	1-7/16	1-3/32							
6	6 5/8	6.065	20-13/16	10-13/32	5-3/16	3-15-32	2-5/8	1-3/4	1-5/16							
8	8 5/8	7.981	27-1/8	13-9/16	6-3/4	4-1/4	3-3/8	2-1/4	1-11/16							
10	10 3/4	10.02	33-3/4	16-7/8	8-7/16	5-5/8	4-1/4	2-13/16	2-1/8							
12	12 3/4	12	40-1/16	20-1/32	10	6-11/16	5	3-5/16	2-1/2							
14	14	13.25	44	22	11	7-5/16	5-1/2	3-11/16	2-3/4							
16	16	15.25	50-1/4	25-1/8"	12-9/16"	8-3/8"	6-5/16	4-3/16	3-1/8							